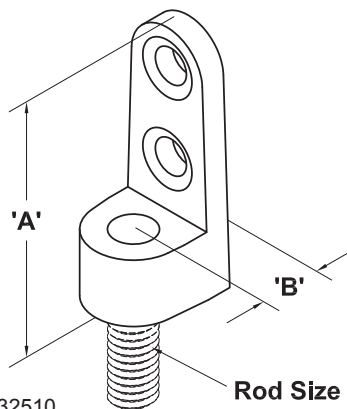

FIGURE 7501 - Beam Connector



Finish: Plain
Per: MSS SP-58, type 34
Material: Malleable Iron,
ASTM A47 Grade 32510

Hanger rod not included

Catalog Number	Rod Size	A	B
FNW7501PC	3/8"-16	2.19"	0.56"

Rod Size	Finish	Max. Load	Wt. (Oz.)
3/8"-16	Plain	250 Lbs.	1.80

FIGURE 7502 - Beam Ceiling Flange

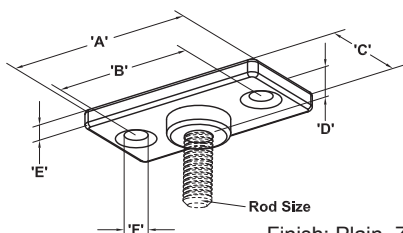

Finish: Plain, Zinc, Stainless Steel, or
Copper
Material: Malleable Iron, Stainless Steel
ASTM A47 Grade 32510

Hanger rod not included

Rod Size	A	B	C	D
3/8"-16	2.75	2.00	1.36	0.46
1/2"-13	2.75	2.00	1.36	0.46

Rod Size	E	F	Wt. (Oz.)
3/8"-16	0.21	0.29	2.88
1/2"-13	0.21	0.29	2.88

Catalog Number	Finish	Rod Size	Max. Load (Lbs.)
FNW7502PC	Plain	3/8"-16	180
FNW7502ZC	Zinc	3/8"-16	180
FNW7502SC	Stainless Steel	3/8"-16	180
FNW7502CC	Copper	3/8"-16	180
FNW7502PD	Plain	1/2"-13	180
FNW7502ZD	Zinc	1/2"-13	180
FNW7502SD	Stainless Steel	1/2"-13	200
FNW7502CD	Copper	1/2"-13	180

FIGURE 7310 - Rigid/EMT Clamp

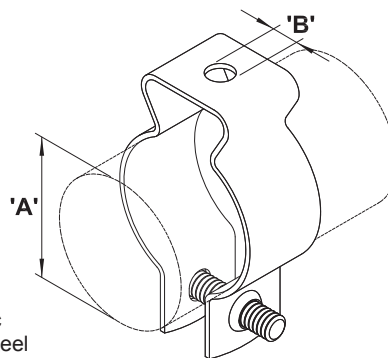

Finish: Zinc
Material: Steel

Notes:

- Sizes 0050 to 0200 have embossed threading for clamp screw.
- Sizes 0250 & 0300 use nut and bolt.
- Sizes 0250 & 0300 have an embossment around hole 'B'.

Catalog Number	Sizes (in.)		A	B	Gauge	Design Load
	Rigid	EMT				
FNW7310Z0050	3/8	1/2	0.80	0.28	18	200 lbs.
FNW7310Z0075	3/4	3/4	1.00	0.28	18	200 lbs.
FNW7310Z0100	1	1	1.20	0.28	18	200 lbs.
FNW7310Z0125E		1-1/4	1.50	0.28	18	200 lbs.
FNW7310Z0125	1-1/4	1-1/2	1.70	0.28	18	200 lbs.
FNW7310Z0150	1-1/2		1.87	0.34	18	200 lbs.
FNW7310Z0200	2	2	2.25	0.34	18	350 lbs.
FNW7310Z0250	2-1/2	2-1/2	3.00	0.41	14	350 lbs.
FNW7310Z0300	3	3	3.50	0.41	14	350 lbs.

FIGURE 7311 - Copper Pipe Clamp

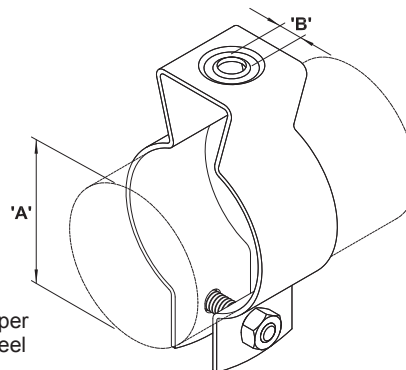

Finish: Copper
Material: Steel

Notes:

- Copper plating is for identification purposes only.
- All sizes use nut and bolt.
- All sizes have an embossment around hole 'B'.

Catalog Number	Copper Sizes (in.)	A	B	Gauge	Design Load
FNW7311C0050	1/2	0.65	0.28	19	200 lbs.
FNW7311C0075	3/4	0.87	0.28	18	200 lbs.
FNW7311C0100	1	1.20	0.28	18	200 lbs.
FNW7311C0125	1-1/4	1.38	0.28	18	200 lbs.
FNW7311C0150	1-1/2	1.70	0.34	16	200 lbs.
FNW7311C0200	2	2.13	0.34	16	200 lbs.