



# 64-Point Analog/Addressable Life Safety System FX-64



FDNY  
APPROVAL  
#6020

## Overview

The FireworX FX-64 life safety system offers the reliability of analog/addressable fire detection for small to mid-sized applications. Built to provide years of trouble-free service, this system benefits building owners and installers with rotary device addressing, optional Ethernet® connectivity, and a full line of easily-to-configure option cards and modules.

The FX-64 provides one Class B analog/addressable device loop that supports up to 64 device addresses, and two Class B Notification Appliance Circuits (NACs). Optional Class A device wiring is available with the use of a module.

The FX-64 supports a wide range of accessories and related equipment, including:

- Intelligent modules and pull stations
- Intelligent detectors, and bases
- Remote annunciators
- Option cards that expand system capacity and extend system capabilities.

## Features

- Comes standard with one loop that supports up to 64 analog/addressable devices of any type and two Class B NACs
- Form C contacts for alarm and trouble, Form A for supervisory
- Rotary addressing
- Optional Ethernet port for diagnostics, programming and a variety of system reports
- Two programmable switches with LEDs and custom labeling
- Supports horn silence over two wires and UL 1971-compliant strobe synchronization
- Optional Class A wiring
- Supports up to eight serial annunciators, (LCD, LED-only, and graphic interface).
- Can use existing wiring for most retrofit applications
- Upload/download remotely or locally
- Two-level maintenance alert reporting
- Pre-alarm and alarm verification by point
- Adjustable detector sensitivity
- 4 x 20 character backlit LCD display
- Optional earthquake hardening: seismic Importance Factor 1.5

## Application

The FX-64 life safety system is a reliable analog/addressable solution for small to mid-sized buildings. Analog/Addressable Technology delivers the benefits of flexible system installation, while a clean and easy-to-operate user interface makes panel operation and system maintenance quick and intuitive.

### Reliability you can count on

The inherent fault-tolerant characteristics of Analog/Addressable Technology boosts the reliability of FX-64 systems. When combined with FX Series smoke and heat detectors, this system delivers a level of dependability not previously available for small to mid-sized applications. All FX systems are built to exacting UTC Fire and Safety reliability benchmarks and meet ISO 9001 standards for quality, in addition to agency listings for dependability.

### Flexibility built right in

Two fully-programmable front panel switch/LED combinations provide an added measure of flexibility. Their slide-in labels take the mystery out of custom applications, and present a clean finished appearance.

### Perfect for retrofits

The FX-64 is particularly well-suited to retrofit applications. All connections are made over standard wiring – no shielded cable required. This means that in most situations existing wiring can be used to upgrade a legacy control panel to FX-64 technology without the expense or disruption of rewiring the entire building.

### Signals with a difference

FX-64 NACs are configurable to fully support UTC Fire and Safety notification appliances. These devices offer precision synchronization of strobes to UL 1971 standards. Enabling this feature allows connected horns to be silenced while strobes on the same two-wire circuit continue to flash until the panel is reset.

### Clear-cut remote annunciation

Remote annunciation is a strong suit of the FX-64. Up to eight annunciators can be installed on a single system. Compatible annunciators include a range of LED and LCD models that provide zone or point annunciation, as well as common control capabilities.

The FX-64 also supports graphic annunciation with optional RA Graphic Annunciator interface modules. Each interface provides common control, indicators, and 32 LEDs. Consult the Ordering Information section for details.

### A complete line of accessories

The FX-64 life safety system is supported by a complete line of analog/addressable detectors, modules and related equipment. Consult the Ordering Information section for details.

## Operation

The front panel provides an easy-to-use operator's interface, as well as all the necessary controls for front panel programming. A large back-lit 80-character LCD displays system status, event details, and programming prompts. Large tactile control buttons are easy to see in low light conditions, and bright multi-color LEDs offer at-a-glance status indication.

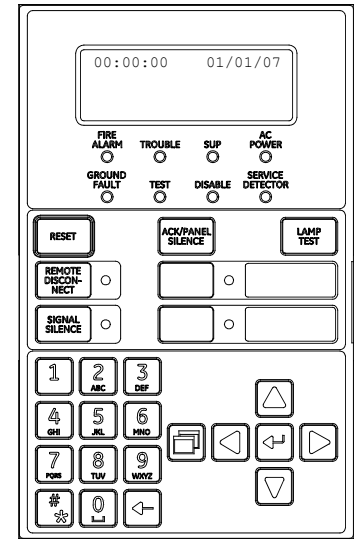

### Control buttons

Button	Description
Reset	Initiates a system reset.
ACK/Panel Silence	Silences the panel and remote annunciators during an active trouble, supervisory, or alarm event and acknowledges new event activations.
Signal Silence	<i>Alarm mode:</i> Silences active notification appliances. Pressing Signal Silence a second time turns NACs back on.
Remote Disconnect	<i>Dialer:</i> Disables or enables dialer. <i>Dialer set to modem only:</i> Disables or enables the common alarm relay.
Left arrow	<i>Display mode:</i> Moves the cursor to the left. <i>Menu mode:</i> Toggles between programming selections.
Right arrow	<i>Display mode:</i> Moves the cursor to the right. <i>Menu mode:</i> Retrieves a programming option's sub menu and toggles between a programming option's selections.
Up arrow	<i>Display mode:</i> Advances to the previous event. <i>Menu mode:</i> Moves the cursor up.
Down arrow	<i>Display mode:</i> Advances to the next event. <i>Menu mode:</i> Moves the cursor down.
Enter	<i>Display mode:</i> Displays selected event details. <i>Menu mode:</i> Retrieves a programming option's sub menu or jumps to the <i>Save</i> function in the menu. <i>Entry mode:</i> Enters the selected data into the system.
Cancel	<i>Display mode:</i> Exits the detailed information display. <i>Menu mode:</i> Exits the current menu level. <i>Entry mode:</i> Clears the current entry.
Menu	<i>Display mode:</i> Enters the menu mode <i>Menu mode:</i> Exits menu mode
Space	Enters a space, such as a space between words.
Alphanumeric keypad	<i>Entry mode:</i> Pressing a button once enters the number on the button. Pressing the button twice enters the secondary value.
Programmable buttons	These buttons can be programmed to control or operate a device, zone, or Panel NAC. The buttons can be labeled with a slip-in insert.

## System LEDs

LED	Description
Fire Alarm	Red LED. On steady when there is an active alarm.
Trouble	Yellow LED. Flashes when there is a fault on a monitored circuit or system component, or when a circuit is disabled.
Supv	Yellow LED. On steady when there is an active supervisory event.
AC Power	Green LED. On when the panel has AC power.
Disable	Yellow LED. Double-flashes when there is a disabled circuit, alarm relay, or remote annunciator.
Ground Fault	Yellow LED. On steady during an active ground fault.
Test	Yellow LED. Flashes when performing an audible walk test. Steady indicates a silent test.
Service Detector	Yellow LED. Indicates that detector needs servicing.
Signal Silence	Yellow LED. On steady indicates that NAC circuits are turned off but the panel is still in alarm.
Remote Disconnect	Yellow LED. On steady indicates that the dialer is disabled or that the alarm relay is enabled or disabled when the dialer is set to modem only.
User keys	Yellow LED. Programmable.

## Panel Operation Options

Language	English or French
Marketplace	U.S. or Canada
AC fail delay	<i>Off:</i> Off-premise notification of an AC power failure is immediate. <i>1 to 15 hours:</i> Delays the off-premise notification of an AC power failure by the time period selected.
Zone resound	<i>On:</i> NACs resound each time a device in the zone goes into alarm even if they were silenced <i>Off:</i> Inhibits the NACs from turning on again (after they were silenced) when a second device in the zone goes into alarm.
Reset inhibit after NACs turn on	<i>Off:</i> Panel reset is operational immediately. <i>1 minute:</i> Panel reset is inhibited for one minute.
Auto signal silence	<i>Off:</i> Allows immediate silencing of signals from an off-normal condition using the Signal Silence button <i>5 to 30 minutes:</i> Delays the silencing of signals from an off-normal condition by disabling the Signal Silence button for the time period selected.
Day start	Start time for daytime sensitivity
Night start	Start time for nighttime sensitivity
Date	<i>U.S.:</i> MM/DD/YYYY <i>Canada:</i> DD/MM/YYYY
LCD banner	Banner text for line one and line two. Each line is capable of up to 20 characters.
Event notification	<i>Zone:</i> When a device is a member of a zone, only the zone information is sent to the LCD display, LEDs, printer, and dialer. <i>Zone/device:</i> Zone information is sent to the LCD display and LEDs. Device information is sent to the printer and dialer. <i>Device:</i> Only device information is reported.

## Programming

FX-64 life safety systems are simple to set up, yet also offer programming features that put these small building panels into a class of their own. Auto programming quickly gets the panel operational using factory default settings and basic zone and point settings can be programmed through the front panel interface, so the system is up and running in no time.

FX-64 systems also interface to a PC running compatible FX-CU software. This option offers full system configuration in the familiar Windows® operating environment. Connection is typically made to a laptop through the panel's optional RS-232 communications port, which can also be used to connect a system printer.

The optional network card provides a standard 10/100 Base T Ethernet® network connection that permits access to the control panel from any remote location with the correct communications protocols. The connection can be used to download to the panel from the FX-CU, or upload and view system reports using the FX-CU.

Available system reports include:

- Correlation groups
- Device details
- Device maintenance
- History
- Internal status
- System configuration
- System status
- Walk test
- Dialer

## Dimensions

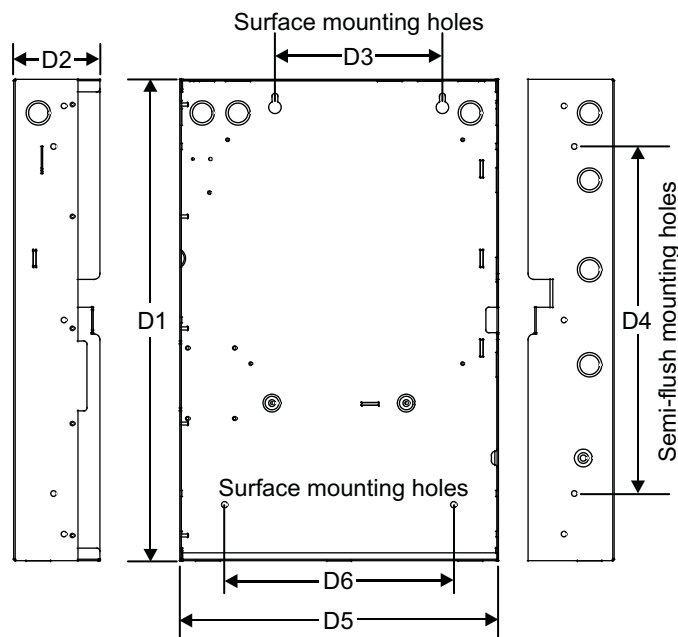

Panel dimensions, in (cm)						
Model	D1*	D2	D3	D4	D5*	D6
FX-64	21.50 (54.6)	3.85 (9.8)	7.5 (19.0)	15.5 (39.4)	14.25 (36.2)	10.25 (26.0)

\* Add 1-1/2 in. (3.81 cm) to D1 and D5 dimensions for trim kit.

# Wiring & Configuration

## Notification appliance circuits (TB2)

The FX-64 comes equipped with two notification appliance circuits. Each circuit can be individually configured for continuous, temporal, synchronized, and coded output.

### Circuit Specifications

Circuit Type	2 Class B, Class A optional when Class A card is installed. Each circuit is 2.5 amps.
Voltage	24 VFWR
Current	3.75 A FWR total at 120/230 VAC 60 Hz 3.0 A FWR total at 230 VAC 50 Hz 2.5 A max per circuit
Impedance	26 Ω total, 0.35 μF max
EOLR	15 K Ω, ½ W

Class B wiring

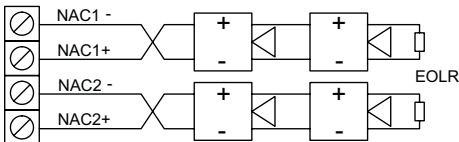

Marking indicates output signal polarity when the circuit is active. Polarity reverses when the circuit is not active. Wire notification appliances accordingly. Notification appliance polarity shown in active state.

## Alarm, trouble, and supervisory relay (TB3)

The trouble relay is normally-open, held closed, and opens on any trouble event or when the panel is de-energized. The supervisory relay is normally-open, and closes on any supervisory event. The alarm relay changes over on any alarm event.

### Relay specifications

	Alarm	Trouble	Supervisory
Type	Form C		Form A
Voltage	24 VDC at 1 A resistive	24 VDC at 1 A resistive	

Relay circuits can only be connected to power-limited sources.

## Auxiliary & Smoke power outputs (TB3)

The control panel provides two auxiliary power outputs which can be used for powering ancillary equipment such as remote annunciators and two wire smoke detectors. Aux 2 can be software selected to operate continuous. The circuit is supervised for shorts and grounds.

Note: For a complete list of devices that can be connected to this circuit, refer to the FX Series Compatibility List 3101063.

### Circuit specifications

Circuit voltage range	21.9 to 28.3 V
Resettable circuit (Aux power 2)	24 VDC nominal at 500 mA
Continuous circuit (Aux power 1)	24 VDC nominal at 500 mA. Use this circuit for powering two-wire smoke detectors.

Note: Any current above 0.5 amp connected to both Aux 1 and 2 will reduce the total available NAC power by that amount.

## Annunciator loop (TB4)

The control panel provides a connection for up to eight serially driven and supervised remote annunciators.

### Circuit specifications

Device loops	Class B (Style Y) or Class A* (Style Z)
Circuit voltage	2.55 V
Circuit current	30 mA max
Circuit	Up to 8 annunciators or 4000 feet, 18AWG wire impedance

### Class B

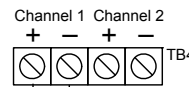

### Class A

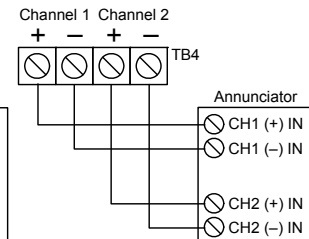

## Option Cards

FireworX panels are supported by a complete line of modules and related equipment that enhance performance and extend system capabilities. Option cards are easy to install and set up. They simply plug directly into the control panel main circuit board or are connected to it with a ribbon cable. After installation, terminals remain easily accessible for quick connection of field wiring. The cabinet provides ample room for wire routing, keeping wiring neat and easy to service at all times.

### SA-CLA Class A Module

The SA-CLA card provides Class A capability for NAC wiring. Its terminal block provides the wiring connection for NAC return wiring. The card is required for loop and annunciator Class A wiring even though this wiring does not return to the SA-CLA card. The SA-CLA is compatible with FX-64 control panels only. FX-254 panels are Class A ready. The SA-CLA is installed directly to the control panel circuit board using its plastic standoffs and plug connection.

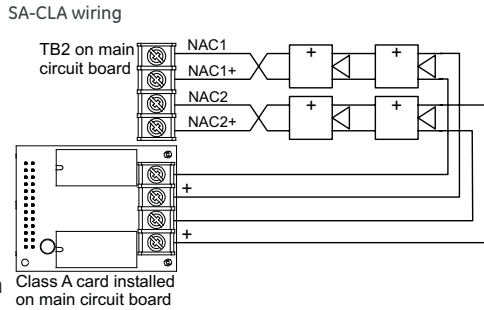

#### SA-CLA specifications

Operating voltage	24 VFWR
Operating current	3.75 A FWR total at 120/230 VAC 60 Hz 3.0 A FWR total at 230 VAC 50 Hz 2.5 A max per circuit
Circuit impedance	26 ohms, 0.35uF
Terminal rating	12 to 18 AWG (0.75 to 2.5 sq mm)
Operating environment	
Temperature	32 to 120°F (0 to 49°C)
Humidity	0 to 93% RH, noncondensing at 90°F (32°C)

### SA-232 RS-232 interface

The SA-232 card provides an RS-232 interface with FireworX panels. It can be used for connecting a printer to the control panel to print system events. The card also can be used for connecting a computer to download a configuration program from the FX-CU to the control panel.

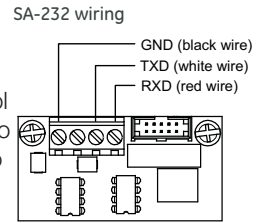

The RS-232 card is installed on the plastic assembly and connects to the main circuit board via a ribbon cable.

#### SA-232 specifications

Operating voltage	Standard EIA-232
Terminal rating	12 to 18 AWG (0.75 to 2.5 sq mm)
Operating environment	
Temperature	32 to 120°F (0 to 49°C)
Humidity	0 to 93% RH, noncondensing at 90°F (32°C)

### SA-ETH Ethernet Interface Card

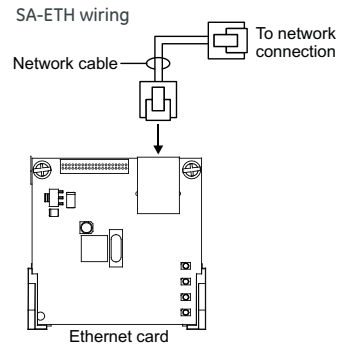

The SA-ETH card provides a standard 10/100 Base T Ethernet network connection for connecting to an intranet, a local network, or the Internet. The card can be used to download configuration programming from the FX-CU to the panel over the network.

The Ethernet card is installed on the plastic assembly and connects to the main circuit board via a ribbon cable.

#### SA-ETH specifications

Ethernet	10/100 Base T
Operating environment	
Temperature	32 to 120°F (0 to 49°C)
Humidity	0 to 93% RH, noncondensing at 90°F (32°C)

## SA-DACT Dialer

The SA-DACT provides communications between the control panel and the central station over a telephone line system. It transmits system status changes (events) to a compatible digital alarm communicator receiver over the public switched telephone network. The dialer is capable of single, dual, or split reporting of events to two different account and telephone numbers. The modem feature of the SA-DACT can also be used for uploading and downloading panel configuration, history, and current status to a PC running the FX-CU.

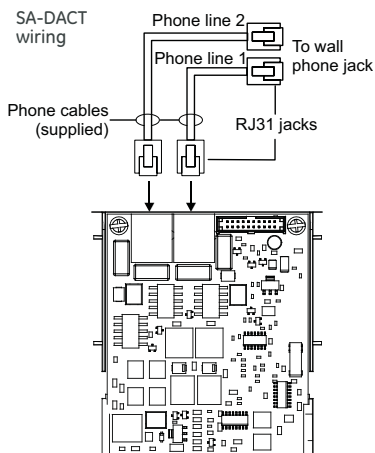

The dialer phone lines connect to connectors on the dialer's main circuit board. Phone line 1 connects to connector J4 and phone line 2 connects to connector J1.

The SA-DACT queues messages and transmits them based on priority (alarm, supervisory, trouble, and monitor). Activations are transmitted before restorations.

The SA-DACT is installed on the plastic assembly and connects to the main circuit board via a ribbon cable.

### SA-DACT specifications

Phone line type	One or two loop-start lines on a public, switched network
Phone line connector	RJ-31/38X (C31/38X)
Communication formats	Contact ID (SIA DC-05)
Operating environment	
Temperature	32 to 120°F (0 to 49°C)
Humidity	0 to 93% RH, noncondensing at 90°F (32°C)

### Compatible DACRs

Receiver	Models	Formats
Ademco	685	Contact ID
FBII	CP220	Contact ID
Osborne-Hoffman	OH 2000	Contact ID
Radionics	D6600	Contact ID
Silent Knight	9800	Contact ID
Sur-Gard	SG-MLR1, MLR2	Contact ID

## Specifications

Device loops	1 loop Class B, Class A optional, supporting up to 64 device addresses
Notification appliance circuits	2 Class B, Class A optional, 2.5 amps each
Power supply	3.75 A FWR total at 120/230 VAC 60 Hz 3.0 A FWR total at 230 VAC 50 Hz 0.5 amps aux power
Operating voltage	24 VDC. NAC minimum voltage: 19.5 VDC @ 20.4 V battery voltage
Loop circuit operating voltage	20 V peak-to-peak
Primary power	120 VAC, 60 Hz, 230 VAC 50-60 Hz
Aux Power 1 (Continuous circuit)	24 VDC nominal at 500 mA
Aux Power 2 (Resettable circuit)	24 VDC nominal at 500 mA.
Auxiliary output	19 to 25.7 VDC
Base panel current draw	Standby: 155 mA Alarm: 204 mA
Battery placement	FX-64 cabinets accommodate up to 10 A/H batteries. Use an external cabinet for larger battery sizes.

Batteries	Batteries must be sealed lead acid type only. Maximum charging capacity = 26 Ah.
Loop circuit	Maximum loop resistance: 66 Ω. Maximum loop capacitance: 0.5 μF. Style 4, 6, and 7 wiring. 64 isolators maximum
Compatibility ID	100
Alarm contact	Form C 24 VDC @ 1 A (resistive load)
Trouble contact	Form C 24 VDC @ 1 A (resistive load)
Supervisory contact	Form A 24 VDC @ 1 A (resistive load)
Environmental	Temperature: 0 to 49°C (32 to 120°F). Humidity: 0 to 93% RH, noncondensing
Terminal rating	All terminals rated for 12 to 18 AWG (0.75 to 2.5 sq mm)
Serial communications	Voltage: 2.55 V. Current: 30 mA max
Remote annunciator	8 drops max, RS-485 Class B, Class A
Input zones	16 max.
Agency Listing	UL, CSFM, ULC and FDNY # 6020

## Ordering Information

Part	Description
------	-------------

### FX-64 Single Loop Systems

FX-64RD	1 Loop System, 64 point capacity, 2 Class B NACs, 2 Line Dialer, Red Door, surface mount enclosure, 115VAC transformer, English.
FX-64R	1 Loop System, 64 point capacity, 2 Class B NACs, Red Door, surface mount enclosure, 115VAC transformer, English.
FX-64GD	1 Loop System, 64 point capacity, 2 Class B NACs, 2 Line Dialer, Gray door, surface mount enclosure, 115VAC transformer, English.
FX-64G	1 Loop System, 64 point capacity, 2 Class B NACs, Gray door, surface mount enclosure, 115VAC transformer, English.
SA-TRIM1	Flush mount trim, black

### Option Cards

SA-DACT	Dual Line Dialer/Modem, supports Contact ID, mounts in cabinet on base plate.
SA-232	Serial Port (RS-232), for connection to printers & computers, mounts in cabinet to base plate
SA-ETH	Ethernet Port, Slave, mounts in cabinet on base plate.
SA-CLA	Class A adapter module. Provides Class A capacity on NACs. Mounts in cabinet on main board.

### Remote Annunciators (refer to Data Sheet 85005-0128)

#### LCD Remote Annunciators

RLCD-R	Remote Annunciator, 4X20 LCD & Common Indicators for displaying system status, mounts 4" Square electrical box, red housing.
RLCD-CR	Remote Annunciator, 4X20 LCD, Common Indicators & Common Controls for displaying system status, mounts 4" Square electrical box, red housing.

#### LED Remote Annunciators & Expander

RLED-CR	Remote Annunciator, Common Indicators for displaying system status, common controls & 16 groups w/2 LEDs each for zone display, mounts to standard 4" Square electrical box, red housing.
RLED24R	Remote Annunciator Zone expander, 24 groups of 2 LEDS each for display of alarm and trouble. Each with custom label area. Mounts to standard 4" electrical box, red housing.

#### Graphic Annunciator Drivers

GCI	Graphic Annunciator Driver, provides outputs for common indicators and 32 alarm/supv zones as well as inputs for common switches. Provided with a snap track for mounting in custom graphic enclosures.
-----	---

#### Remote Annunciator Cabinets & Accessories

RA-ENC1	Remote Annunciator Enclosure, key locked with plexiglass window for one RLCD(C) or RLED(C).
RA-ENC2	Remote Annunciator Enclosure, key locked with plexiglass window with space for 2 of either RLCDx, RLEDx or RLED24.
RA-ENC3	Remote Annunciator Enclosure, key locked with plexiglass window with space for 3 of either RLCDx, RLEDx or RLED24.
RKEY	Keyswitch, single gang, provides key operated enable or disable of common controls on RLCD or RLED units.
LSRA-SB	Surface Mount Box - for R-Series Annunciators.

#### Programming Tools

FX-CU	FireworX configuration and diagnostics utility.
-------	---

Continued...



Contact us...

Email: [edwards.fire@fs.utc.com](mailto:edwards.fire@fs.utc.com)  
 Web: <http://fireworx.edwardsfire.com/>

FireworX is an **EDWARDS** brand.  
 1016 Corporate Park Drive  
 Mebane, NC 27302

© 2013 UTC Fire & Security Americas Corporation, Inc. All rights reserved. Specifications subject to change without notice. Edwards is part of UTC Climate, Controls & Security, a unit of United Technologies Corporation.

## Analog/addressable Devices & Accessories

Part Number	Description	Ship wt.
-------------	-------------	----------

### Analog/addressable Detectors & Bases (refer to data sheet FX85001-0592)

FX-PHD	Analog/addressable Optical/Fixed Temperature Detector	0.25 (0.11)
FX-PD	Analog/addressable Optical Smoke Detector	0.25 (0.11)
FX-HD	Analog/addressable Fixed Temperature Heat Detector	0.25 (0.11)
B4U	Standard Base	0.11 (0.05)
RB4U	Relay Detector Base	0.11 (0.05)
IB4U	Isolator Detector Base	0.11 (0.05)
SB4U	Audible (Sounder) Detector Base	0.11 (0.05)
AB4G-SB	Surface Box for Audible Base	1.0 (0.45)
RLED	Remote alarm LED, use with standard base only	0.2 (.09)

### Modules

FX-270	Single action pull station	
FX-278	Double action pull station	
FX-IDC1B	One Input Module, mini	
FX-IDC2B	Two Input Module, double gang	
FX-IDCWS	Two Input Module, double gang, Waterflow, Supervisory	
FX-RLY	Analog/addressable relay Module, double gang	
FX-ISO	Line isolator Module	
FX-NAC	Analog/addressable NAC Module, double gang with FireworX strobe synchronization	
FX-IDC1A	One input, class A module, double gang	
FX-2WIRE	Two-wire Smoke Detector Interface Module, double gang	

### Accessories

CTM	City Tie Module. Mounts in 2-gang electric box. Provides connection to a local energy fire alarm box.	0.6 (0.3)
MFC-A	Multifunction Fire Cabinet, 8" x 14" x 3.5" - RED.	20.6 (9.4)
BC-1	Battery Cabinet. 14.0" x 18.25" x 7.25". Holds 2 12V24A batteries.	50.0 (22.7)
BC-1R	Battery Cabinet - Red. 14.0" x 18.25" x 7.25". Holds 2 12V24A batteries.	50.0 (22.7)
BC-1EQ	Seismic hardening Kit for iO series panels. Includes battery hardening for BC-1 enclosure and components to harden panel internal components. See note.	

### Note:

For earthquake anchorage, including detailed mounting weights and center of gravity detail, please refer to Seismic Application Guide 3101676-EN. Approval of panel anchorage to site structure may require local AHJ, structural, or civil engineer review.

Standby batteries must be mounted externally from fire panel in separately mounted BC-1 enclosure. Order BC-1 and BC-1EQ separately.