

# EMERGENCY BACKUP INSTRUCTIONS

EMG-LED-G2-10W/EMG-LED-G2-10W-FLEX  
EMG-LED-G2-10W-LP/EMG-LED-G2-10W-FLEX-CP  
EMG-LED-G2-10W-INTG-FLEX/EMG-LED-G2-20W-INTG-FLEX  
EMG-LED-G2-20W-EMG-LED-G2-20W-FLEX



CLASS 2  
OUTPUT

## IMPORTANT SAFEGUARDS

- 1.** Do not join battery connector or turn "ON" the battery switch until installation is complete and AC power is supplied to the emergency driver.
- 2.** This product is intended for use with an emergency LED lighting load and supplies nominal of power and a maximum voltage in emergency mode for a minimum of 90 minutes.
- 3.** An unswitched AC power source is required (115-277 VAC, 50/60 Hz) to power these units
- 4.** This product 's chassis must be grounded.
- 5.** This product is suitable for use in damp locations where the ambient temperature is 0°C minimum, to 60°C maximum. This product is also suitable for installation in sealed and gasleted fixture. This product is not suitable for heated air outlets and wet or hazardous locations. For the 10W models, maximum allowable case temp is 66°C For the 20W models, maximum allowable case temp is 70 °C. See the section of this document for TC measurement location.
- 6.** This product contains a rechargeable LiFePO4 battery. The battery must be recycled or disposed of properly.
- 7.** Make certain all connectors are in accordance with the National Electrical Codes or Canadian Electrical Code and any local regulations.
- 8.** This emergency LED driver is suitable for both factory or field installation. For field installation, please see the instructions section.
- 9.** Do not install near gas or electric heaters.
- 10.** The use of accessory equipment is not recommended by the manufacturer may cause an unsafe condition.
- 11.** Do not use this product for anything other than it's intended use.
- 12.** Equipment should be mounted in locations and at heights where it will not be subjected to tampering by unauthorized personnel.
- 13.** For Canadian applications, the output terminal should be in compliance with the accessibility requirement of the Canadian Electric Code.
- 14.** This device complies with part 15 of the FCC Rules. Operations is suitable to the following two conditions: (1) This device may not cause harmful interference, and (2) This device must accept any interference that may cause undesired operation.

- 15.** To reduce the risk of electric shock, disconnect both normal and emergency power supplies and place the battery switch in the "OFF" or disconnect the battery connector of the emergency driver before servicing.
- 16.** Do not attempt to service the battery. It is a sealed no maintenance battery is used that is not field replaceable. Contact the manufacturer for information on service.
- 17.** Servicing should be performed by qualified service personnel only.



### Caution:

DO NOT JOIN BATTERY CONNECTOR OR ACTIVE BATTERY SWITCH UNTIL INSTALLATION IS COMPLETE AND AC POWER IS SUPPLIED TO THE EMERGENCY DRIVER.



### Note:

Make sure the necessary branch circuit wiring is available. An unswitched source of power is required. The emergency driver must be fed from the same branch circuit as the AC driver.

This product is suitable for field installation with suitable LED loads. There are Three (3) checks to determine if your luminaire is eligible for field installation.

- 1.** Ensure the LED load's rated power is greater than or equal to the power output of this emergency LED driver. This is to ensure that this emergency product will not produce more power than the LED load can handle. Thus ensuring that the LED load will not be damaged when the system is in the emergency mode.
- 2.** Verify that the forward voltage of the luminaire's LED array is within the limits of this emergency LED driver. The forward voltage of the LED array is commonly designated as Vf and should be found on the luminaire, in the luminaire specifications, or imprinted directly on the LED arrays. If multiple LED arrays are to be driven, verify that the total forward voltage is within the limits of this product. Using a voltage meter, it may be possible to directly measure the voltage across the LED arrays when operating from the AC driver.
- 3.** Ensure the output current of the LED driver does not exceed 5 Amps. This is the current into the red/ blue output wire.



**NOTE:**

This product has been designed to reliably interface with a wide selection of LED loads and is electrically compatible with every simple LED array that meets criteria 1 and 2 above. However compatibility cannot be guaranteed with all current and future LED systems. Compatibility testing of the end-use systems is suggested. Please contact the factory with any questions

**NOTE:**

After installation it will be necessary to measure the egress lighting illumination level to ensure it complies with national state and local code requirement.



Installation of this emergency LED driver will vary based on the luminaire type, however generally follow these steps.

**INSTALLING THE EMERGENCY DRIVER**

1. Disconnect AC power from the LED luminaire.
2. Mount the emergency LED driver by the mounting tabs using appropriate screws (not provided). The luminaire's installation instructions may provide guidance on the recommended mounting location.

Emergency Part#	Application	Notes
EMG-LED-G2-10W	Integrated Mounting	
EMG-LED-G2-10W-FLEX	Remote Mounting	Remote mount test switch
EMG-LED-G2-10W-LP	Integrated Mounting	
EMG-LED-G2-10W-FLEX-CP	Remote Mounting	Flex for Chicago Plenum
EMG-LED-G2-10W-INTG-FLEX	Remote Mounting	Test Switch is integrated, Power Flex
EMG-LED-G2-20W-INTG-FLEX	Remote Mounting	Test Switch is integrated, Power Flex
EMG-LED-G2-20W	Integrated Mounting	
EMG-LED-G2-20W-FLEX	Remote Mounting	

**Mounting Height:** This product meets or exceeds the NFPA minimum light requirements with all loads, down to the smallest rated lamp load, at heights up to 7.17ft (2.2m). Many factors influence emergency illumination levels, such as the lamp load selected, luminaire design, and environmental factors. Therefore end use verification is necessary. For field installations, when the attached luminaire is mounted at heights greater than 7.17ft (2.2m), the level of illumination must be measured in the end application to ensure the requirements of NFPA 101 and local codes are satisfied.

**Remote Mounting:** The emergency LED driver may be remote mounted from the luminaire. If used in conjunction with an AC driver the allowed distance is up to half the distance the AC driver manufacturer recommends remote mounting the AC driver from the LED load. If used without an AC driver, and remote mounting more than 18 feet from the luminaire, please consult the factory to determine the necessary wire gauge.

**CAUTION:** Remote mounting can result in reduced power output.

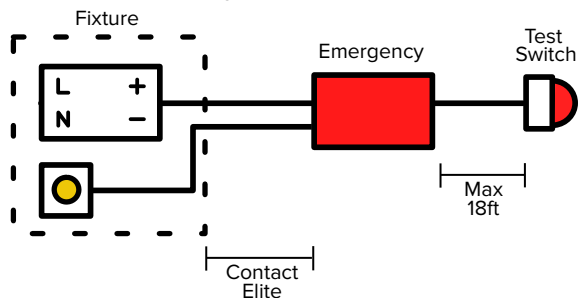
**3.**

Mount the supplied 4 wire illuminated test switch in a location that is visible and accessible by maintenance personnel. The switch mounts through a hole which may need to be added to the luminaire or could come pre-punched by the luminaire supplier.

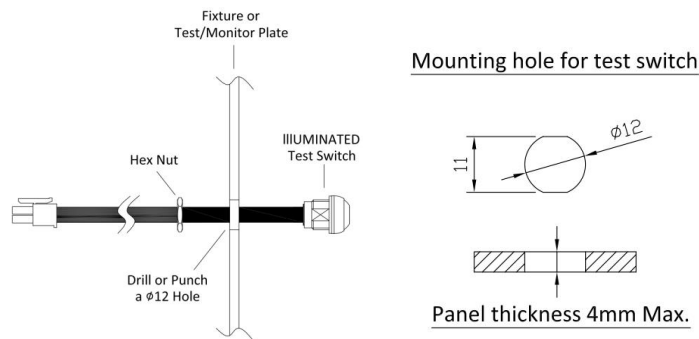
**4.**

Wire the test switch per wiring diagrams provided on this instruction.

**5.**

If wired correctly, the test switch indicator light should be ON when AC power is supplied to the fixture, and the battery switch is "ON" indicating that the emergency battery is charging.

**6.**

Select the appropriate wiring diagram to connect the emergency driver to the AC driver and LED load. Make sure all connections are in accordance with the National Electrical Code and any local regulations. After installation is complete, supply AC power to the emergency driver and turn on battery switch/join battery connector. At this point, power should be connected to both the AC driver and the emergency driver, and the Charging Indicator Light should illuminate indicating the battery is charging.

**NOTE:**

For 10W models, a short term discharge test may be conducted after the emergency driver has been charged for one hour. A 24 hour charging period must be performed before conducting a long term discharge test. For 20W models, a short term discharge test may be conducted after the emergency driver has been charged for one hour. A 48 hour charging period must be performed before conducting a long term discharge test. Refer to the OPERATION section of specs.

**CAUTION:**

This unit has more than one power connection point. To reduce the risk of electric shock, disconnect both the branch circuit breakers or fuses and emergency power supplies before servicing.

**OPERATION**

During normal operation AC power is applied, to the driver, and the charging indicator light is illuminated, which indicates that the battery is being charged. When power fails, the emergency LED driver will automatically switch to emergency power (internal battery), operating the LED load for a minimum of 90 minutes. When AC power is restored, the emergency driver returns to the charging mode.

## MAINTENANCE

Although no routine maintenance is required to keep the emergency driver functional, it should be checked periodically to ensure that it is working. The following schedule is recommended:

- 1.** Visually inspect the charging indicator light monthly. It should be illuminated. If the charging indicator is off. Contact tech support.
- 2.** Test the emergency operation of the fixture at 30 day intervals for a minimum of 30 seconds. The LED load should operate at reduced illumination.
- 3.** Conduct a 90 minute discharge test once a year. The LED load should operate at reduced illumination for at least 90 minutes.

**\*REFER ANY SERVICING INDICATED BY THESE CHECKS TO QUALIFIED PERSONNEL**

## TCASE TEST POINT LOCATION

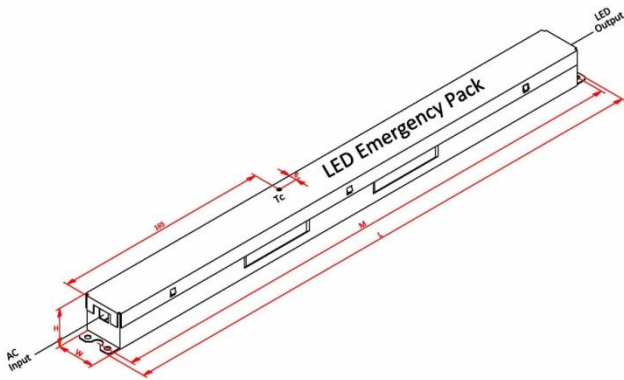

10W Slim Emergency LED Driver

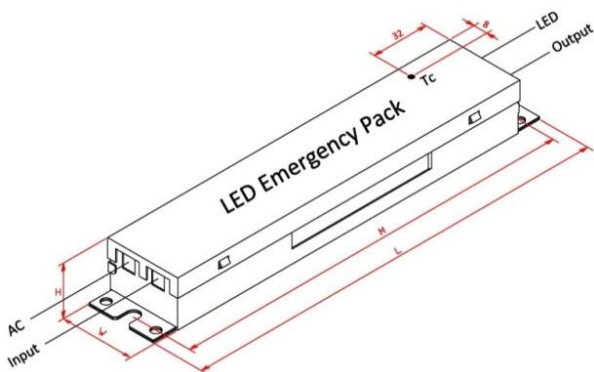

10W Emergency LED Driver

EMERGENCY DRIVER AND AC DRIVER MUST BE FED FROM THE SAME BRANCH CIRCUIT TYPICALLY. IT MAY BE USED WITH OTHER DRIVERS. CONSULT THE FACTORY FOR OTHER WIRING DIAGRAM.

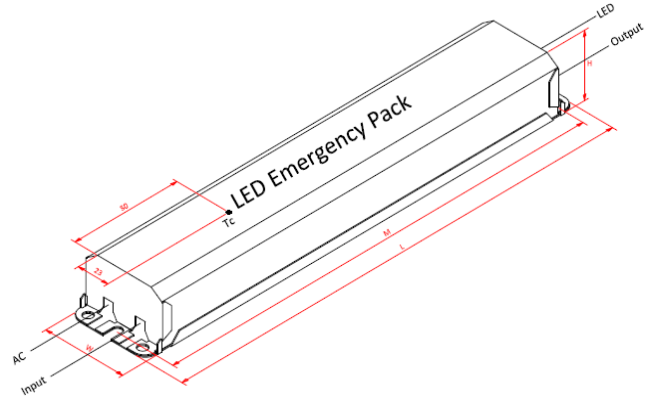

20W Emergency LED Driver

## SYSTEM WIRING DIAGRAM

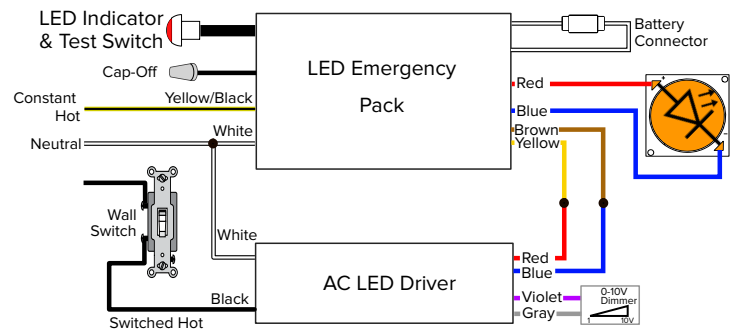

Overall Wiring Diagram

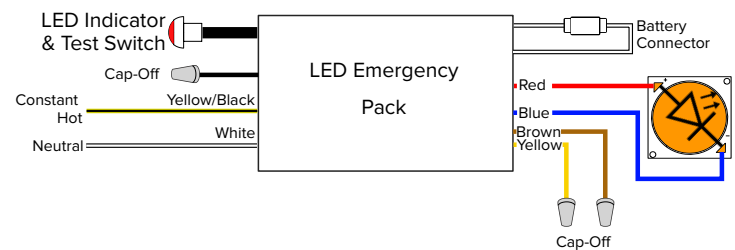

Emergency Only Wiring Diagram

## HIPOT TEST



**Caution:**  
PLEASE FOLLOW THE WIRING DIAGRAM BEFORE DOING HIPOT TEST, OTHERWISE IT MIGHT CAUSE DAMAGE TO THE EMERGENCY DRIVER OR AC DRIVER.

There are two different scenarios for performing hipot test;

- 1) With an AC driver
- 2) Without an AC driver

Wiring diagrams for both scenarios are provided as below. Please follow the wiring diagram before performing hipot testing. The recommended setting is 1.5KV, 5mA/1sec

### Scenario 1: Hipot Test with Emergency LED Driver and AC Driver

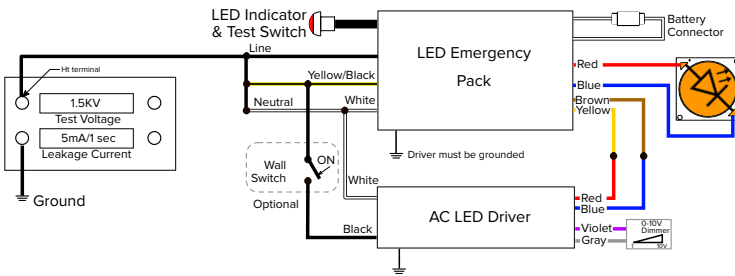

**Fig A: Short all three input wires White, Yellow/Black and Black together**

In Figure A, we short all the input wires White, Yellow/Black and Black wires together. Also, the user must ensure the optional wall switch is "ON". It is safe to begin hipot testing .

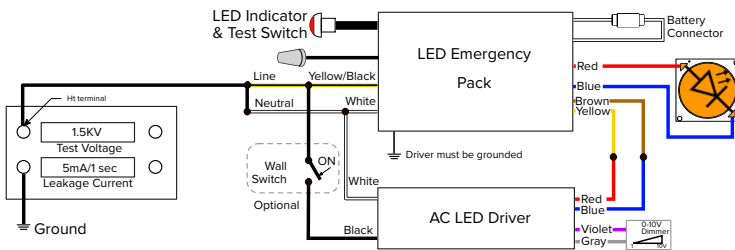

**Fig B: Short all three input wires White, Yellow/Black, Black, and cap off Black from Emergency driver**

In Figure B, all three input wires White, Yellow/Black and Black wire from AC driver are shorted together. Also the user must ensure the optional wall switch is "ON". The black wire from Emergency LED driver should also be "capped off" (left open) It is safe to begin hipot testing.

### Scenario 2: Hipot Test with Emergency LED Driver without AC Driver

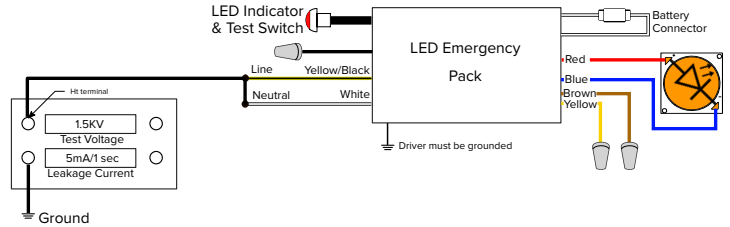

**Fig C: Short two input wires White, Yellow/Black and open Black wire**

In Figure C, two input wires White and Yellow/Black are shorted, and the Black wire is "capped off" (left open). It is safe to begin hipot testing.

## TECHNICAL SPECIFICATIONS

	10W Model	20W Model
<b>Input Voltage</b>	120-277VAC	120-277VAC
<b>Input Current</b>	60mA	70mA
<b>Input Power</b>	10W Max	20W Max
<b>Frequency</b>	50/60Hz	50/60Hz
<b>Output Voltage</b>	15-55VDC	15-55VDC
<b>Output Current</b>	190mA	380mA
<b>Ambient Temperature</b>	0°C - 55°C	0°C - 55°C
<b>Max Case Temperature</b>	66°C	66°C
<b>Battery Type</b>	LiFePO4	LiFePO4
<b>Installation Type</b>	Factory or Field	Factory or Field
<b>Min Duration Time</b>	90min	90min
<b>Recharge Time</b>	24Hrs	48Hrs
<b>Battery Voltage</b>	6.4VDC	9.6VDC
<b>Battery Charge Current</b>	185mA	210mA