

Available Finishes / Materials:

EG -- Electro-galvanized

Standard Finish: EG

Catalog Number	Thread Size	Nut Thickness		A		Wt. lbs
		in	mm	in	mm	
CNW30025EG	1/4"-20	0.37	9.4	0.81	20.6	0.120
CNW30037EG	3/8"-16	0.37	9.4	0.81	20.6	0.113
* CNW40050EG	1/2"-13	0.50	12.7	0.91	23.1	0.130

* Cannot be used with 1 3/16" channel

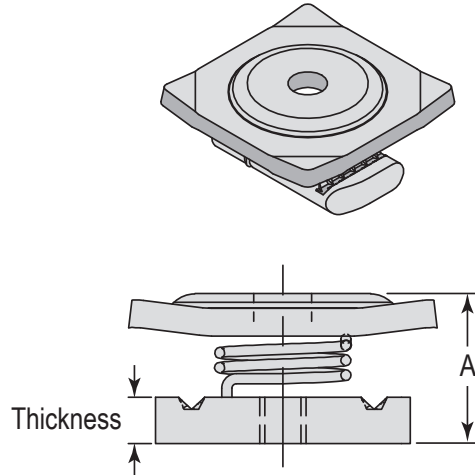

Material Specifications and Finishes

Carbon Steel – ASTM A1011-00 SS GR 33 or ASTM A1011-00CS Type B

EG – Electro-Galvanized. Electroplating deposits zinc on the surface of the steel by electrolysis from a bath of zinc salts. Recommended for relatively dry indoor use.

This is the standard coating for most Jet Stream products. Thickness of applied zinc is between 0.2 mils to 0.5 mils [5.1 µm to 12.7 µm]. Coatings on Jet Stream EG products meet ASTM B633 SC1 Type III.

Note: Specifications subject to change without notice.

Project:	Date:	Phone:
Submitted By:	Address:	
Comment		