



Cat. No. 1064

Strap Mounted Buzzer

Low power drain

1064 & 1065 Series

FEATURES

- > High voltage
- > Adjustable volume
- > Zinc-plated finish
- > Low power drain permits long wire runs
- > 1064 has terminal connectors
- > 1065 has flying leads

Flush mounted, heavy duty buzzer designed for standard outlet box installation. The 1064 Series are provided with terminals for wiring connections. The 1065 Series are provided with flying leads for wiring connections

Installs in standard outlet boxes using any standard wall plate.

Low cost, quality buzzer widely used in homes, apartment houses, plants, and OEMs.

AGENCY APPROVALS

- > UL 464 Listed

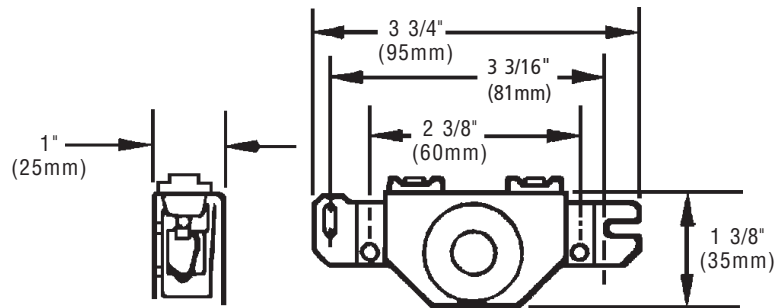

Cat. No. 1064 Shown

Cat No.	Volts	Amps	VA	DC Coil Res (ohms)	dB at 1m / 10 ft.
1064-G5	24V AC 50/60 Hz	0.25A	6	36	82 / 76
1064-N5	120V AC 50/60 Hz	0.05A	6	925	
1064-R5	240V AC 50/60 Hz	0.025A	6	3600	
1065-G5	24V AC 50/60 Hz	0.25A	6	36	82 / 76
1065-N5	120V AC 50/60 Hz	0.05A	6	925	
1065-R5	240V AC 50/60 Hz	0.025A	6	3600	

D-04