

Project:	
Type:	
Catalog #:	

## STANDARD



## FEATURES

- Dedicated housings for most 4" LED trims (compatible with BRK-LED4-BW, BRK-LED4-BW-V2, and BRK-LED4-GR series).
- Suitable for new construction or remodel applications.
- Galvanized steel construction.
- New construction model comes standard with nail for easy install.
- Bar hangers for use with new construction models are adjustable from 13.6" to 25".
- Remodel cans install into existing material with no above ceiling access required.
- Through branch wiring with maximum 6 No. AWG conductors.
- Remodel cans come standard with four torsion clips to secure housing – accommodates 0.5" and 0.6" ceilings.
- Features seven 1/2" NPT knockouts.
- 2-pin quick connector.
- This device is not intended for use with emergency exits.

## WARRANTY & LISTINGS

- cULus listed for damp locations.
- cULus listed for through-branch wiring.
- Title 24 compliant.
- Certified under ASTM-E283 for air-tight construction.
- 5-year warranty of all electronics and housing.

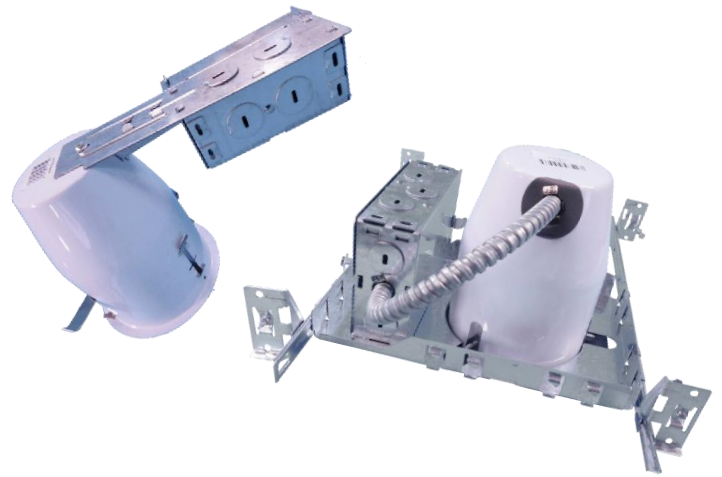

## DIMENSIONS

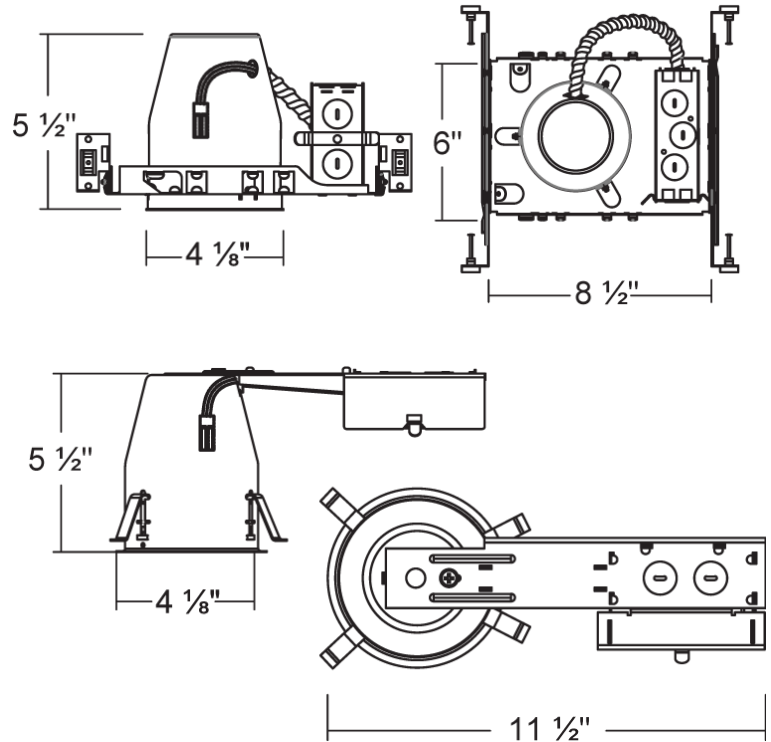

## ORDERING INFORMATION

MODEL	DESCRIPTION
BL4ICLED-NND	4" IC LED DEDICATED CAN FOR NEW CONSTRUCTION
BL4ICLED-RND	4" IC LED DEDICATED CAN FOR REMODEL APPLICATIONS